

Finish type: GCM1 26-655

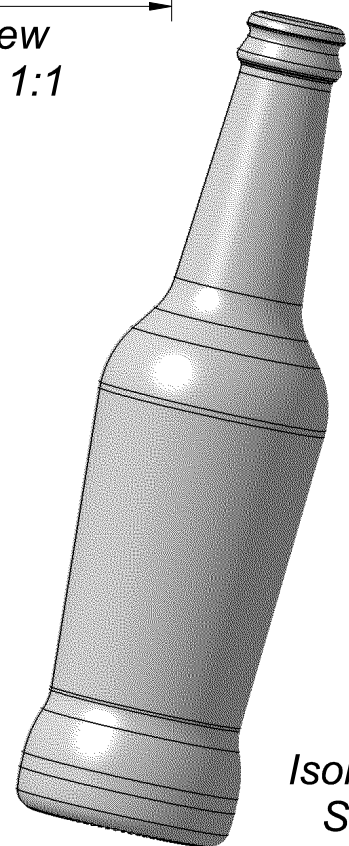
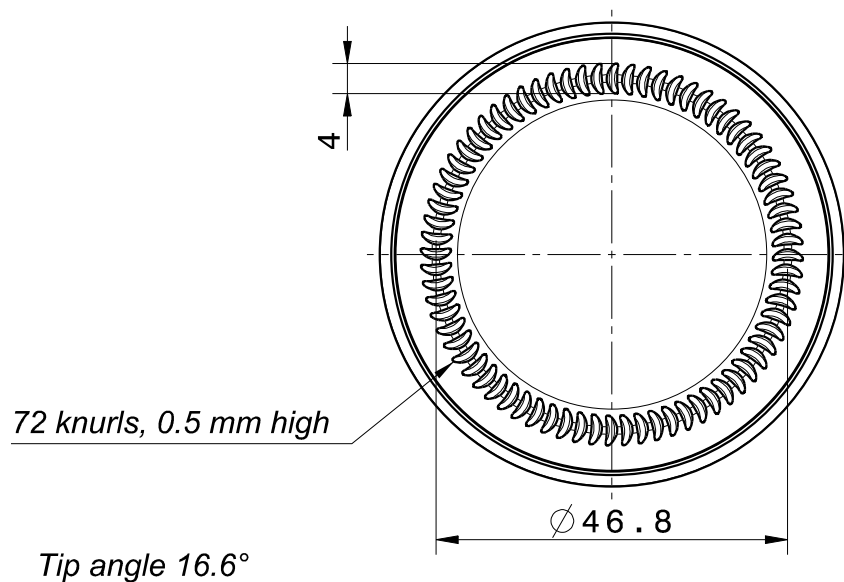
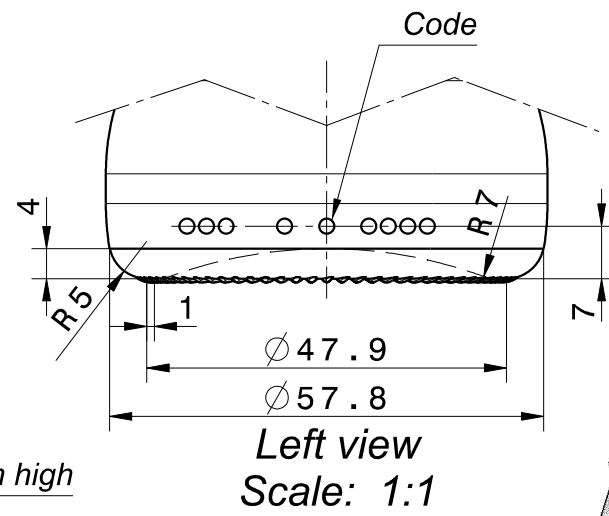
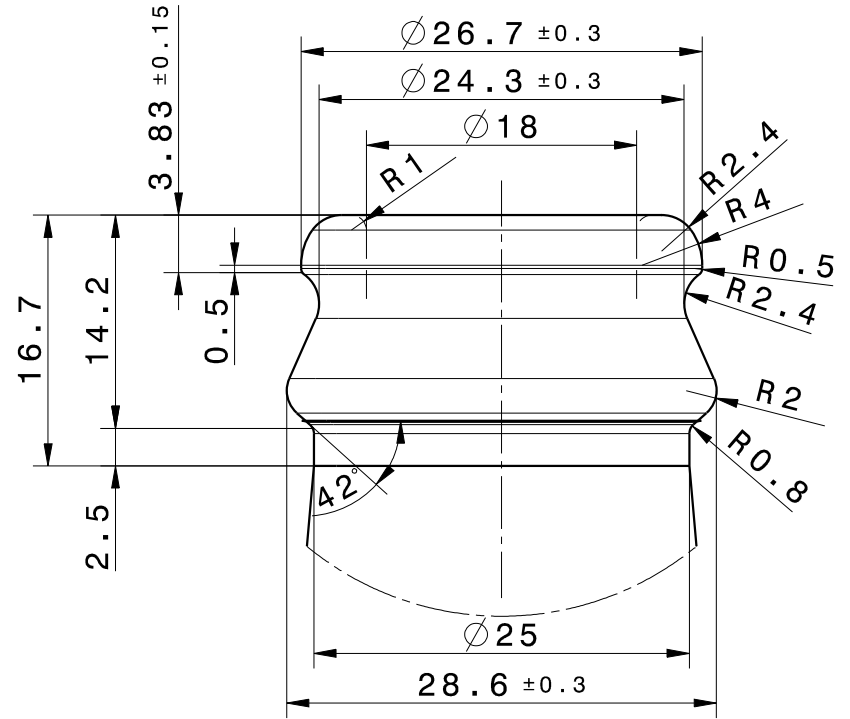

CAPACITY LEVEL FULL		WEIGHT		DESIGNER	DATE	FINISH #1	WALL	NOTE : DO NOT SCALE
310	ML	230	GRM	Frljužec K.	20.01.14.	GCM1 26-655	2.7mm	1 DIMENSIONS SHOW GLASS SIZES. UNTOLERANCED DIMENSIONS ARE NOT SUBJECT TO SPECIFIED LIMITS
CAPACITY AT FILL LINE		GLASS COLOUR		Job. No.	J00000			2 FILLING POINT MEASURED FROM TOP CENTRALLY INSIDE.
300 ± 5	ML			TITLE	COLA 310ml			3 CAPACITY TOLERANCE APPLIES TO BULK TEST MEAN OF 12.
FILL LINE	34 FROM TOP	REF. No.						DRG.No. K00000-SPE-01-1
VACUITY	3.2%							