

NECK FINISH DETAILS
PITCH=3.2

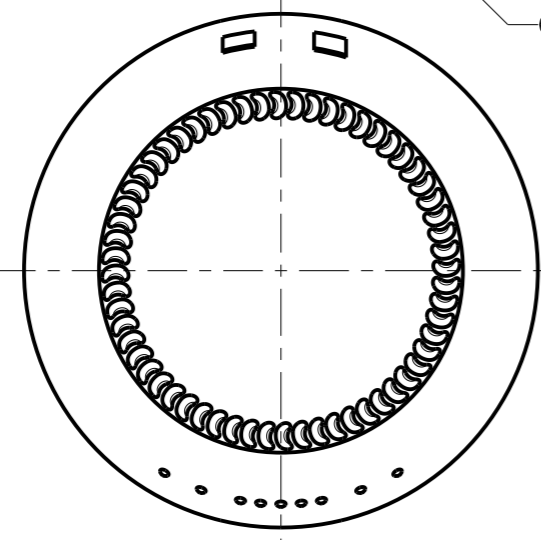

DESCRIPTION	WEIGHT (g)	300±10	SCALE:		EGY GLASS MOULD CO.			
	375ml GHANDOUR BOTTLE	BFC (ml)	395±6	NOT TO SCALE		ALL DIMENSIONS ARE IN MILLIMETER		
DRAWING NO:	FILL CAP (ml)	375±6	DRAWN	DATE:				
	COLOR	FLINT		18.4.17				
	NECK FINISH	30pp EXTRA DEEP	CHECKED	APPROVED				
			REV.NO.	REVISION	DATE	SIGN		