

POINT SECTION 5:1

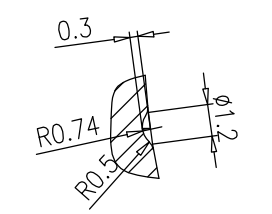

POINT SECTION 5:1

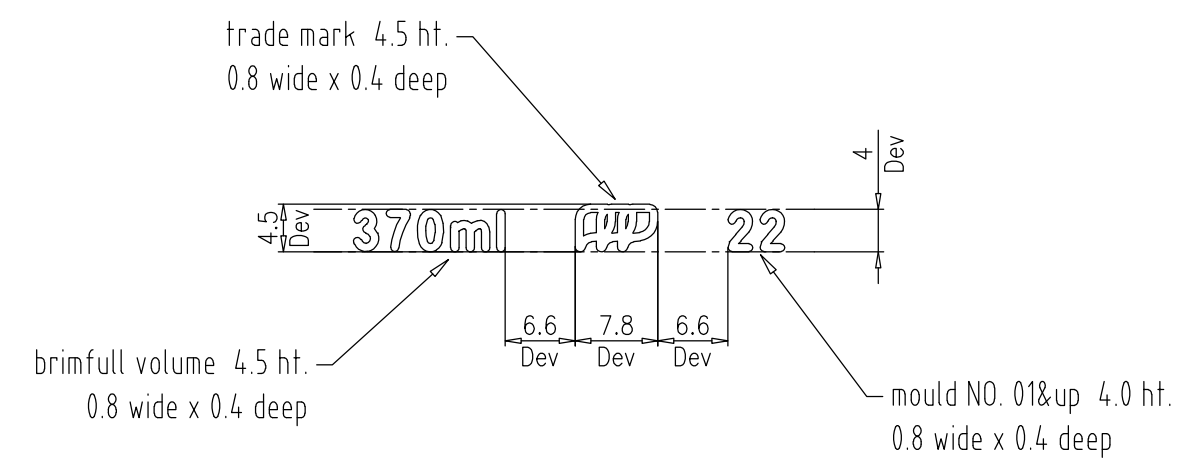
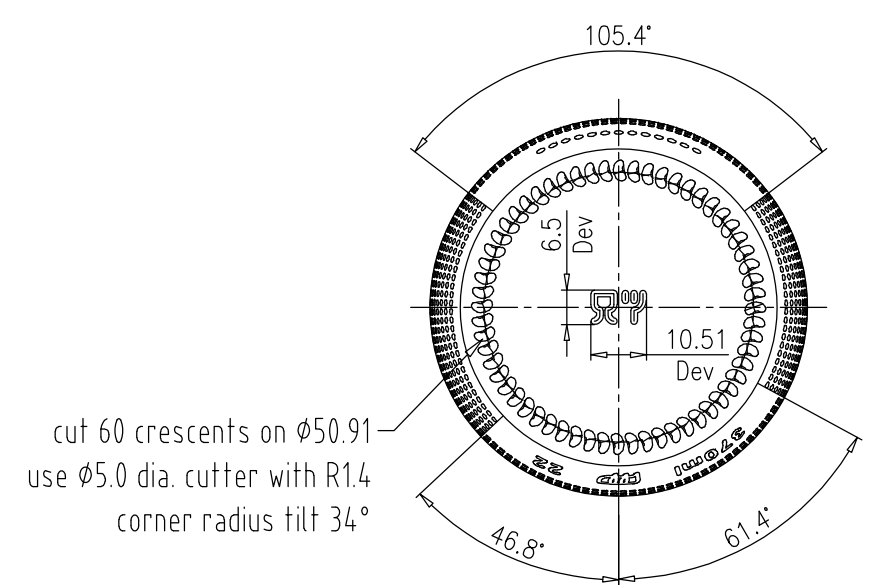

DESCRIPTION :	370ml Jar	STD. WEIGHT :	160 ±7gms	GRAMS NOMINAL	
		BRIMFUL CAPACITY :	370 ±10ml	MILLILITRES	
CUSTOMER :		FILL POINT CAPACITY :		MILLILITRES	BROTHER DRAWN BY : DATE : 20.02.20
CUSTOMER'S APPROVAL :		FILLING POINT :		NOM. HEADSPACE	CHECKED BY : DATE :
DATE :		COLOUR :			APPROVED BY : DATE :
		FINISH :			SCALE: 1 : 1 DRG. NO.:
		A.C.L. DECORATION :			